

# **REINHOLD ENVIRONMENTAL Ltd.**



## **2011 NO<sub>x</sub>-Combustion Round Table & Expo Presentation**

February 7-8, 2011, in Birmingham, AL / Hosted by Southern Company

All presentations posted on this website are copyrighted by Reinhold Environmental, Ltd (RE). Any unauthorized downloading, attempts to modify or to incorporate into other presentations, link to other websites, or obtain copies for any other uses than the training of attendees to RE's Conferences is expressly prohibited, unless approved in writing by RE or the original presenter. RE does not assume any liability for the accuracy or contents of any materials contained in this library which were presented and/or created by persons who were not employees of RE.

# **An Integrated Approach to SO<sub>3</sub> Mitigation and Multi-Pollutant Controls**

**Mark Thomas  
Consultant**

2011 NOx Roundtable Birmingham,  
Alabama

# An Integrated Approach to SO<sub>3</sub> Mitigation and Multi-Pollutant Controls

- GENERAL
  - Interactive Presentation (35-45 min)
    - Questions during presentation OK
  - Discussion/ Q&A (15-25 min)
    - Questions From Audience & For Audience
- OVERVIEW
  - Discuss Interactive Concepts & Strategies
  - Present Some Examples of Integrated Strategies
  - Open Discussion

# INTEGRATED EMISSION CONTROLS

- Not a new concept but significantly more complicated by existing and emerging regulations
- Must evaluate all new significant modifications to major plant systems from an integrated systems standpoint.
  - Primary Plant Systems
  - Pollution Control Systems
  - Waste Systems
- Driven by need to:
  - Resolve existing operations and environmental concerns
  - Leverage potential operations & environmental benefits
  - Comply with existing & new environmental regulations
  - Comply with New Source Review (NSR) requirements
  - Save \$\$

# Speaker Experience & Perspective

- Co-op Ohio Edison (First Energy)
  - Sammis Dry Scrubbing Test (Mid-Late 1980's)
- Employed Cincinnati Gas & Electric>Cinergy>Duke Energy (1990 – 2011)
  - Boilers, Steam Cycle Performance, APH's, Fans, Exp Jt's, Dampers, FGDs, Misc BOP systems
  - Significant Corrosion Related Issues (SO<sub>3</sub>)
- Last 10 Yrs more focused on back end systems
  - SO<sub>3</sub> Mitigation (1999 - current)
  - FGD/ Gypsum Plant
  - SCRs & Catalyst Mgt
- Learned first hand there are many complex interactions that need to be evaluated but usually are not.

# Background for Duke's IECS Efforts

SO3 Mitigation efforts required a comprehensive evaluation of:

- Negative Side Effects
- Co-Benefits
- 1999 Initiated efforts to mitigate SO3 plume at Zimmer
- 2000-2004 Tested various reagents from fuel additives to DSI & Slurry injection at FGD Inlet
- 2004 & 2005 installed permanent SO3 mitigation systems
  - Hydrated Lime
  - Trona
  - SBS/ Soda Ash
  - Furnace Mag Hydroxide Slurry Injection
  - Dual Reagent Systems
- 2006 thru 2010 Additional Reagent Testing for SO3/ Co-Benefits
- 2010 - Current DSI Testing (Trona, SodiumBicarb, Hydrated Lime) for SO2 removal w/FFDC

# Damper Corrosion



# ID Fan Corrosion



## VISIBLE PLUME



- Opacity due to  $\text{H}_2\text{SO}_4$  (Sulfuric Acid) Aerosols in Flue Gas
- Aerosols  $\text{H}_2\text{SO}_4$  in flue gas when quenched in Absorber Mods

# SO<sub>3</sub> Mitigation Impacts

- SO<sub>3</sub> Mitigation Strategies
  - Initially for Acid Aerosol (Blue) Plume Concerns
    - Sorbent Injection Technologies (Dry & Wet)
    - Fuel Additives
    - Fuel Switching
  - Growing Implementation revealing:
    - Challenges & Limitations
    - Co-Benefit Opportunities
    - Unanswered questions

# SO<sub>3</sub> Mitigation Impacts

- SO<sub>3</sub> is a key pollutant with widespread impacts
- SO<sub>3</sub> Mitigation Processes and reagents also can have widespread impacts
- Pollutants including HCl, Hf, Hg, Nox are directly or indirectly impacted
- Significant HCl Reduction Co-Benefit Possible with various Sorbent injection technologies
  - Numerous secondary benefits from HCl mitigation
- Equipment & System Impacts must be evaluated

# EMISSIONS/ ENVIRONMENTAL ISSUES W/ POTENTIAL IMPACTS OR CO-BENEFITS FROM SO<sub>3</sub> MITIGATION

## Air Emissions

- SO<sub>x</sub>
- NO<sub>x</sub>
- Hg
- HCl/ Hf
- HAPS
- CO<sub>2</sub>??

## Water Issues

- NPDES

## Coal Combustion Products

- Fly Ash
- Gypsum

## Landfill Issues

- Leaching
  - Se, As, Al,
- Groundwater

# COMMON OPERATIONAL ISSUES

## Basic Plant Systems

- Boiler
  - Slagging
  - Fouling
  - Water Wall Corrosion
  - Bottom Ash pH
- Air Heater
  - Fouling
  - Corrosion
  - Heat Rate Limitations
- Ductwork & Fans
  - Corrosion
  - Fan Hp & Aux Pwr

## Environmental Systems

- SCR Catalyst
  - Deactivation/ Poisoning
  - SO<sub>2</sub>/SO<sub>3</sub> Oxidation
  - Pluggage
  - Unit & Fleet Dispatch
- ESP Problems
  - Ash Resistivity
  - Corrosion
- FFDC Problems
  - Bag Blinding
  - Bag Failures
- FGD Issues
  - Alloy Corrosion (Chlorides)
  - Excessive Chloride Purge Stream

# SO<sub>3</sub> MITIGATION STRATEGIES

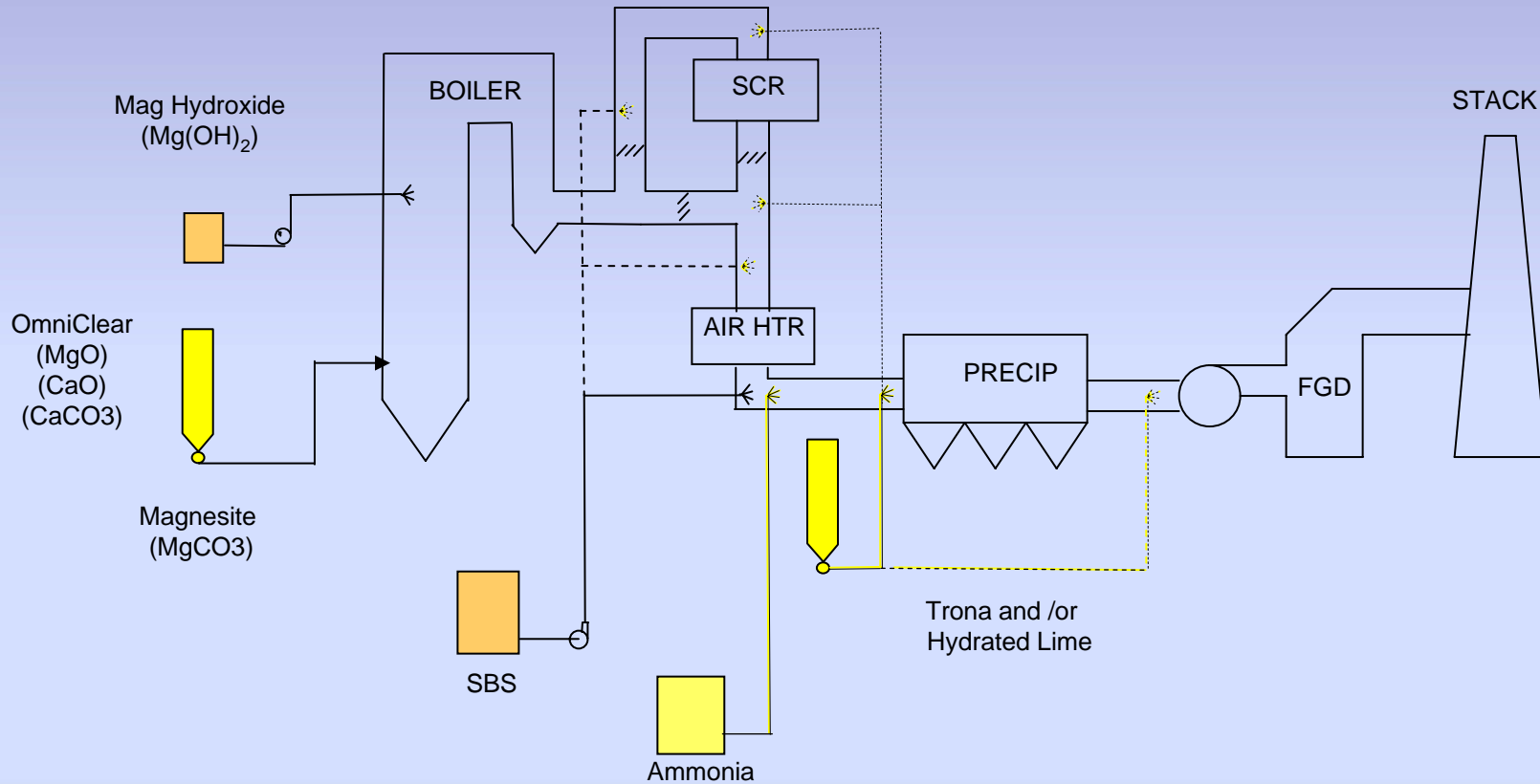

# Examples of IECS Strategies

- SO<sub>3</sub> Mit Pre-SCR
  - Reduced Cat Min Temp Restrictions
  - Potential Arsenic Mitigation Co-Benefit
  - Must evaluate Catalyst Effects
  - Must Evaluate Pre-SCR HCl/ Hg Oxidation impacts
- SO<sub>3</sub> Mit Pre-APH
  - Heat Rate Savings
  - Lower APH Out temps may help ESP Problems
  - Increased NO<sub>x</sub> Removal
  - Air Heater Element Life Extension
  - Reduced Air Heater Washes
  - Extended Catalyst Life
  - Must evaluate potential APH fouling mechanism

# Examples of Potential IECS Strategies

- SO<sub>3</sub>/ Chlorine Removal Co-Benefits
  - Increased Fuel Flexibility
  - Reduced FGD Chlorides (Corrosion & Scrubber Purge)
  - Boiler Chlorine Tolerance
- EPRI Toxecon (ESP + FFDC) w/ Sorbent Injection
- SCR Catalyst Hg Oxidation
- Switch to FGD Inhibited Oxidation with Fixation

# Chlorine Impacts

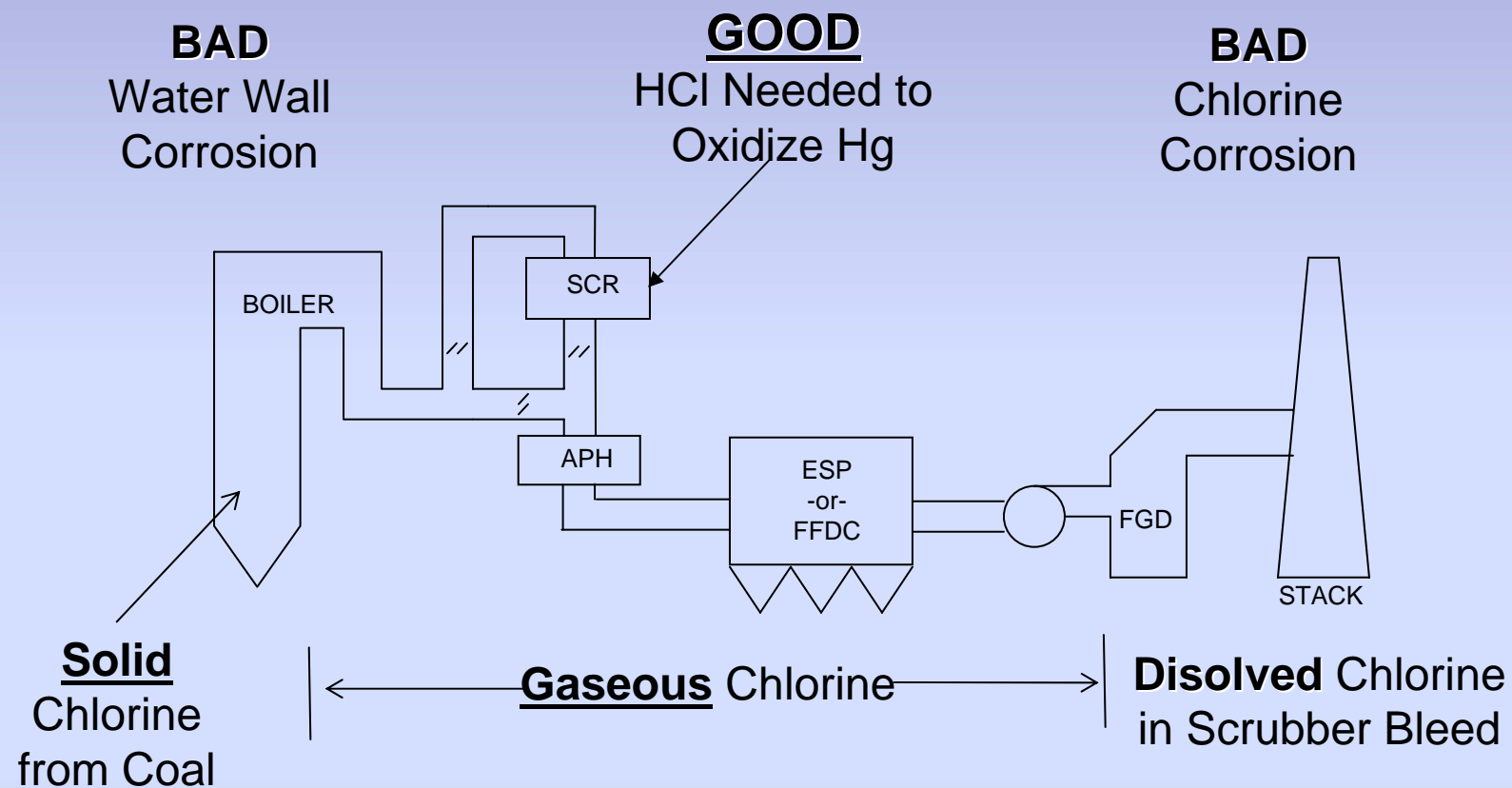

# HCL/ SO3 MITIGATION STRATEGIES

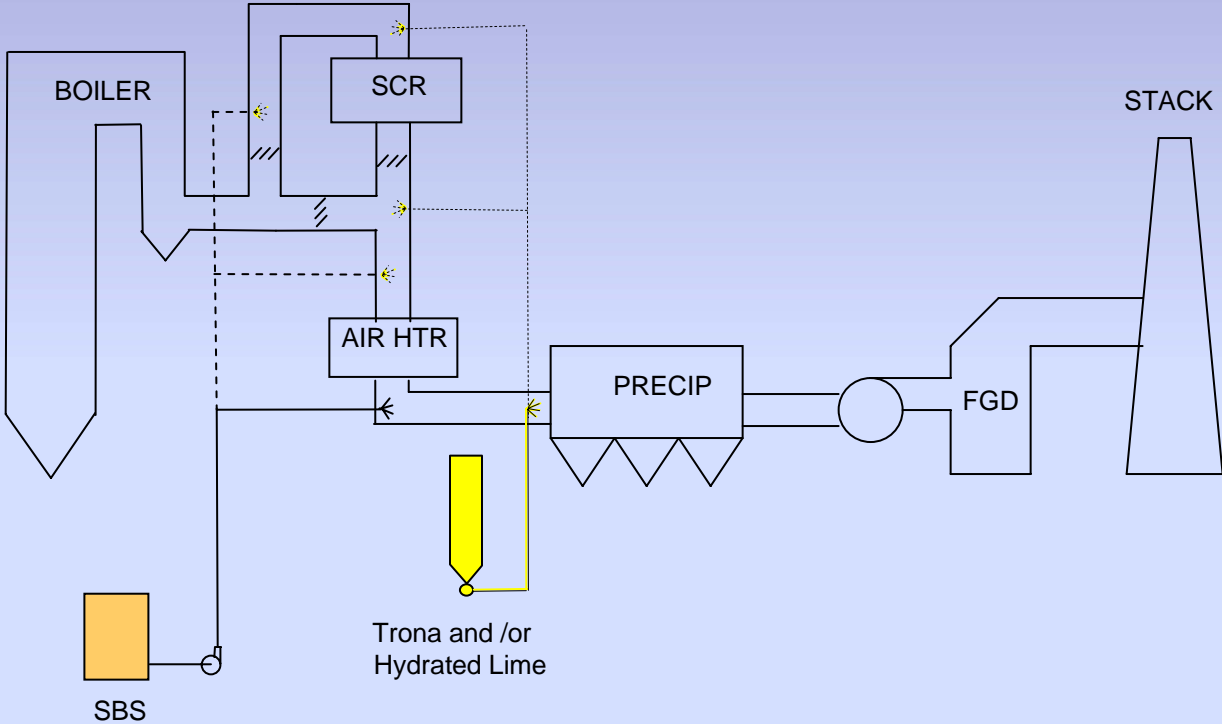

# Basic FGD Mass Balance

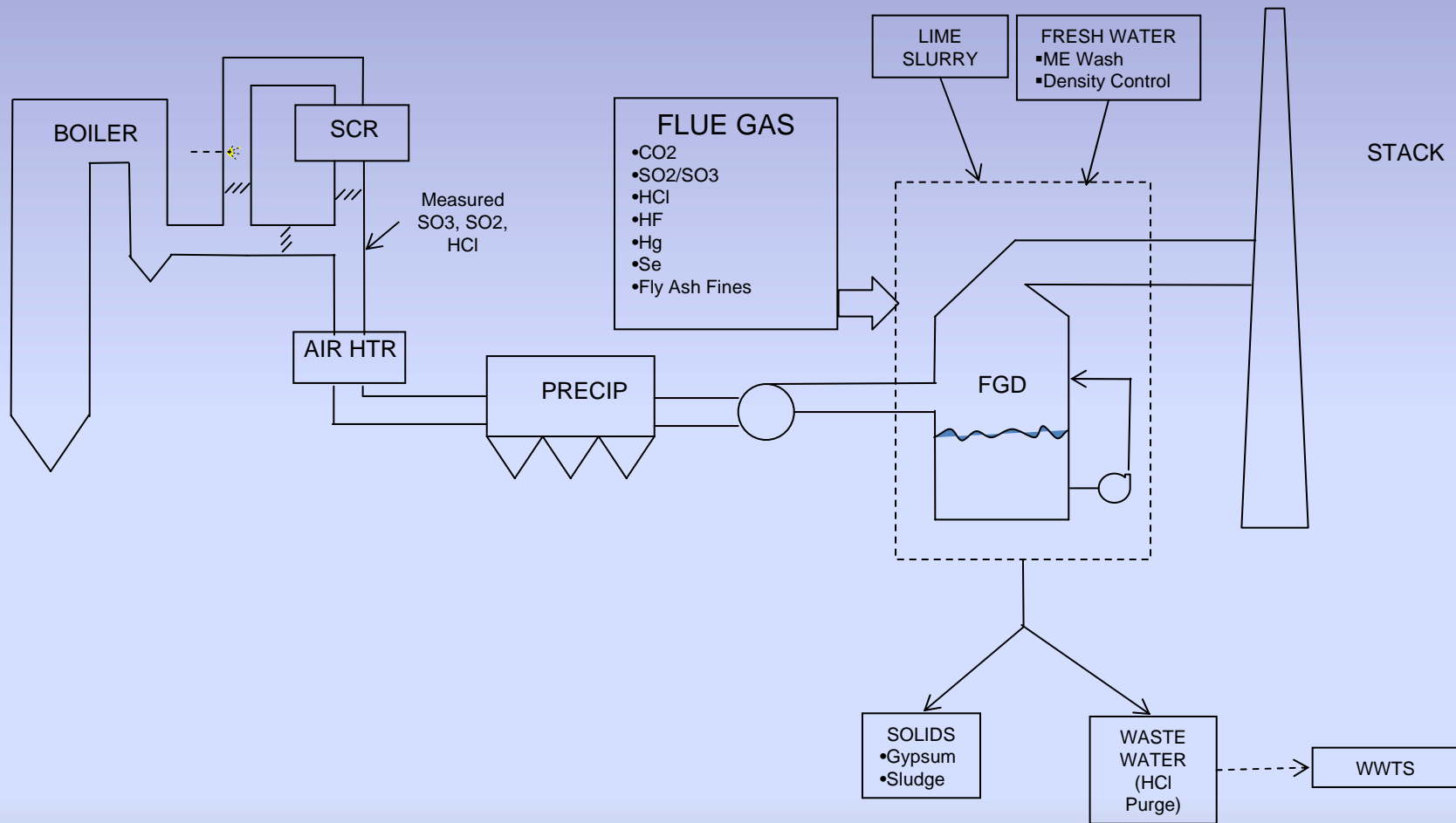

# Duke Cliffside AQCS

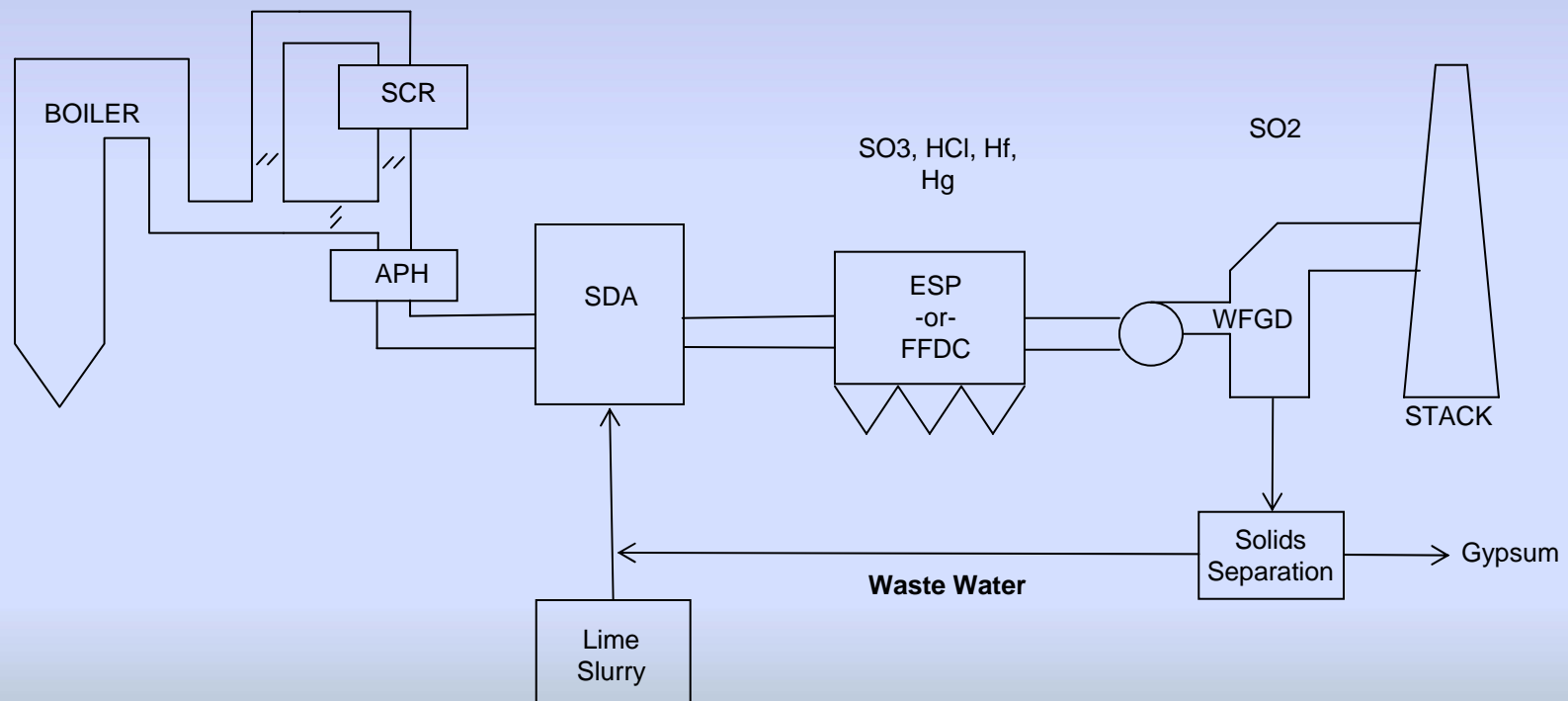

# Concerns with HCl Mitigation

- Higher Reagent Usage Rates
- ESP Impacts
  - Low SO<sub>3</sub> Levels >> High Ash Resistivity
  - Increased Mass Loading/ Maldistribution
- Fly Ash Impacts
  - Fly Ash Sales
  - Landfill Leaching & Structural Issues
- SCR Impacts
  - Catalyst Deactivation
  - Reduced Hg Oxidation

## Testing of Integrated emissions strategies

- Ongoing Industry Testing should provide guidance
- Extent of Integrated Co-Benefits are plant specific
- Often requires on-site testing to confirm extent of Co-Benefits/ problems
- ***NOTE: SITE TESTING MUST BE WELL THOUGHT OUT AND PLANNED***
- Effects on systems and equipment must be considered prior to:
  - Baseline Emissions Testing
  - Reagent Injection Test Campaigns

# Question & Answer

- Contact Info
  - Mark Thomas
  - Cell 513-312-0124
  - [markthomas@fuse.net](mailto:markthomas@fuse.net)

# Questions For Audience

- Does your company do comprehensive IECS evaluation for environmental projects, MACT, CATR, NPDES, etc?
  - In-house? Department or Taskforce?
  - Role of A&E's, Consultants, Vendors?
- What Examples do you have of IECS & what are tradeoffs?
- What obstacles to proceeding with IECS ideas?
- Examples of where failure to consider IECS impacts led to significant problems?